

SPECIFICATION SERIES

PROJECT _____
 TYPE _____

13" RECESSED INCAN A-LAMP LENS LIGHT

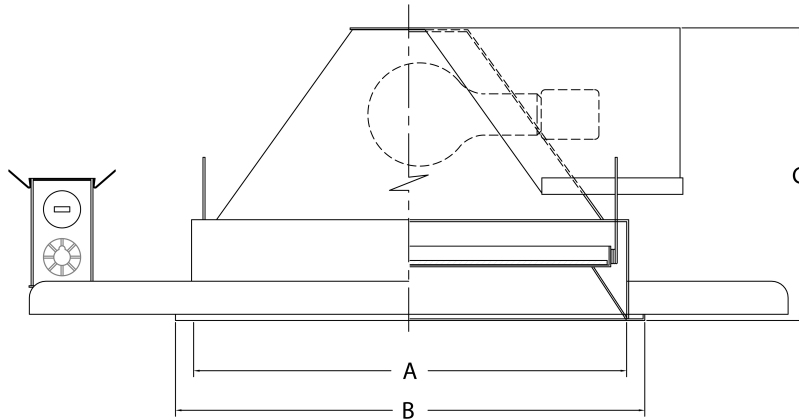

FEATURES:

- LOW IRIDESCENT REFLECTOR
- HEAVY EXTRUDED ALUMINUM HEAT SINK
- GALVANIZED STEEL FRAME
- SUITABLE FOR THROUGH BRANCH CIRCUIT WIRING
- FACTORY PRE-WIRED FOR EASY INSTALLATION
- INSULATION DETECTOR

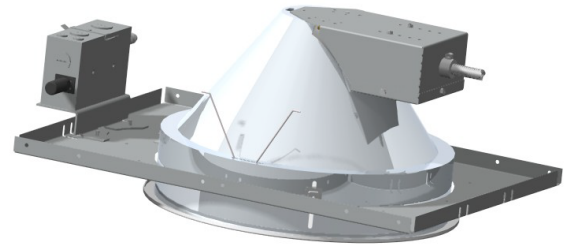

	A	B	C	LENGTH	WIDTH	CUT OUT
INCH	13.25	14.25	9.00	20.00	16.25	13.50
MM	336.55	361.95	228.60	508.00	412.75	342.90

ORDER INFORMATION:

SERIES	LAMP	VOLTS	REFLECTOR	TRIM	COLOR	LENS	OPTION	OPTION
SP-HIAL13	100W	120	CL	CLW	MTL	CGL	TP	CP
	150W			MWT	WHT	C73	F	WET
	200W				BLK	FNL		
	300W				BRZ			

OPTIONS:

CL	CLEAR		WHT	WHITE POWDER COAT DOOR
CLW	CLEAR WHITE TRIM		BLK	BLACK POWDER COAT DOOR
MWT	MATTE WHITE TRIM		BRZ	BRONZE POWDER COAT DOOR
277	277 VOLTS*		TR	TAMPER PROOF DOOR*
CGL	CLEAR GLASS LENS*		F	FUSE
C73	CORNING PATTERN 73 LENS		CP	CHICAGO PLENUM*
FNL	FRESNEL LENS		WET	UL WET LOCATION*
MTL	BRUSHED/POLISHED ALUMINUM DOOR			

* PLEASE CONSULT FACTORY

LIGHT ONE, INC. P.O. BOX 389-PLAINFIELD, IL 60544 • TEL:773-7478100 • FAX:773-747-8778

WWW.LIGHTONEINC.COM