

# PENDANT SERIES

PROJECT \_\_\_\_\_  
 TYPE \_\_\_\_\_

# INDUCTION SYSTEM LOW BAY 16"

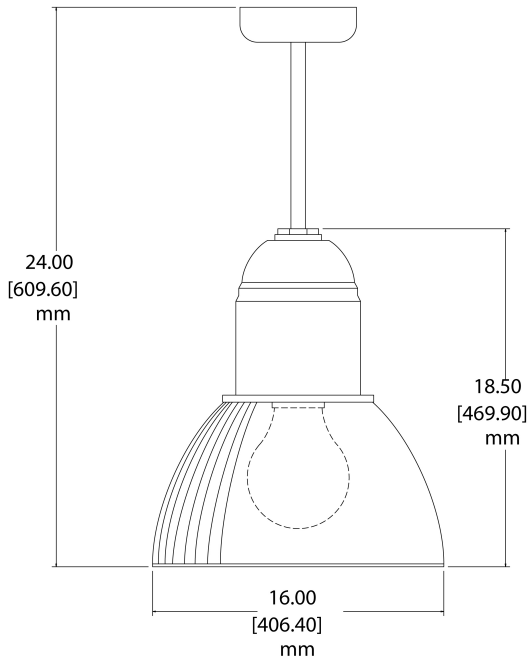

## FEATURES:

- HIGH IMPACT FLUTED REFLECTOR
- HEAVY GAUGE SPUN ALUMINUM HOUSING
- FACTORY PRE-WIRED FOR EASY INSTALLATION
- STANDARD COLORS: BLACK, BRONZE & WHITE
- FOR UL WET LOCATION CONSULT FACTORY
- LONG LIFE OF 100,000 HOURS
- HIGH COLOR RENDERING INDEX (CRI) > 80

ORDER	MOUNT	SERIES	COLOR	LAMP	VOLTS	REFLECTOR	OPTION	OPTION
	P	ISLB16	MTL	55W	120/277	CL	SAG	WET
			WHT	85W		DF	K12	
			BLK	100W			WG	
			BRZ	120W				
			165W					

OPTIONS	P	PENDANT MOUNT**	DF	DIFFUSED ACRYLIC
	MTL	BRUSHED/POLISHED ALUMINUM	CGL	CLEAR GLASS LENS**
	WHT	WHITE POWDER COAT	SAG	SAG ACRYLIC LENS
	BLK	BLACK POWDER COAT	K12	K12 ACRYLIC LENS
	BRZ	BRONZE POWDER COAT	WG	WIRE GUARD
	CL	CLEAR	WET	UL WET LOCATION**

LAMP	WATTS	INPUT VOLTS	INITIAL LUMENS	LM/W	CRI	COLOR	HOURS
	35W	120/277V	2450LM	66	>80	5000K*	100,000
	55W	120/277V	3575LM	62	>80	5000K*	100,000
	85W	120/277V	5950LM	67	>80	5000K*	100,000
	100W	120/277V	7000LM	67	>80	5000K*	100,000
	120W	120/277V	9000LM	71	>80	5000K*	100,000
	165W	120/277V	11550LM	67	>80	5000K*	100,000



\* 5K TEMPS STANDARD STOCK COLOR-AVAILABLE TEMPS 2720-6500K  
 \*\* PLEASE CONSULT FACTORY